



Personalized Web Learning: Merging Open Educational Resources into Adaptive Courses for Higher Education

Peter A. Henning

Aalborg/2014-07-11

Problems of MOOCs



- High number of participants, but also high number of dropouts, 90%
 - Rigidity of MOOC learning: „One-size-fits-them-all“
 - Different learning goals inadequately known and taken care of
 - How can we reduce this number of dropouts ?
 - still, 10% of 28.000 participants is a very large number

- Cost of production rather high
 - 50.000 € or \$ minimum
 - Almost impossible to keep up to date
 - Not adequate for higher education teaching

Small OER



- Small Open Educational Resources on the rise
 - Most of them very small, e.g.
 - short texts with expert content
 - Short videoclips (3-5 min) explaining something
 - Seminar/conference videos

- Can we join these small OER into concise courses offered for free
- Possibility A: Physical merge => lose all advantages
- Possibility B: Website with links => what concept ?
- Possibility C: Join them dynamically according to learner's needs.
 - Extend Learning Management Systems LMS

INTUITEL System - Software



- EU Project
<http://www.intuitel.eu>
 - 12 partners
- Extend 5 market relevant LMS (ILIAs, Moodle, Clix, eXact, Crayons)
 - Up and running
- New meta data format SLOM
 - Link content which is semantically annotated
- Software will be available also in a royalty-free version

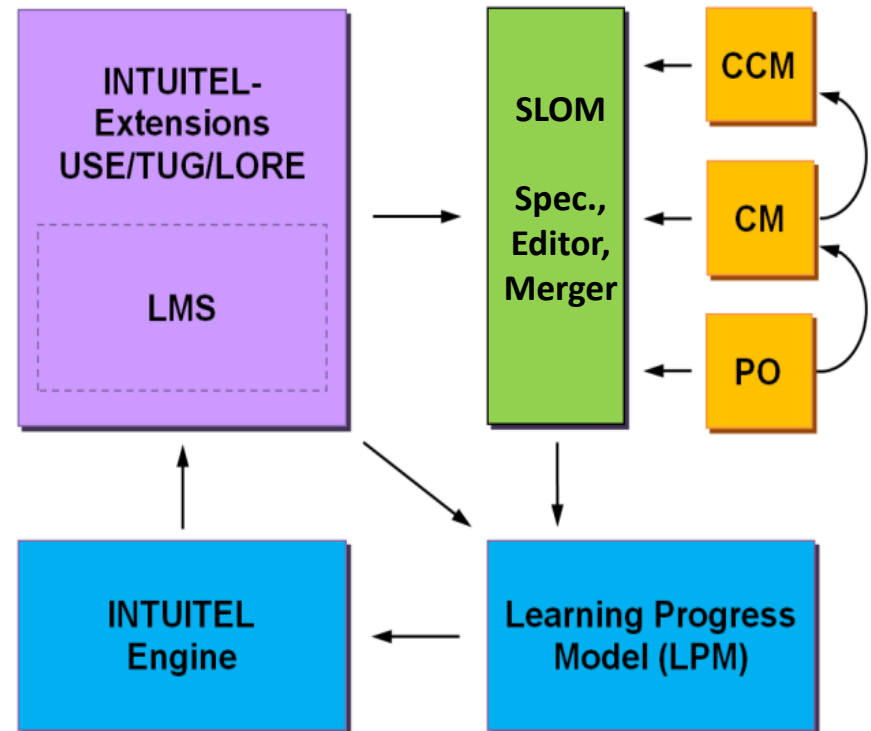

INTUITEL System - Knowledge



- Pedagogical Ontology:
 - Terms and relations from pedagogical science, written as OWL file
- Cognitive Maps:
 - Domain of knowledge, CM are concrete instantiations of the pedagogical ontology.
 - Concept container and macro learning pathways (MLP)
- Cognitive Content Maps:
 - Associate the learning content to the cognitive map
 - Micro learning pathways μ LP

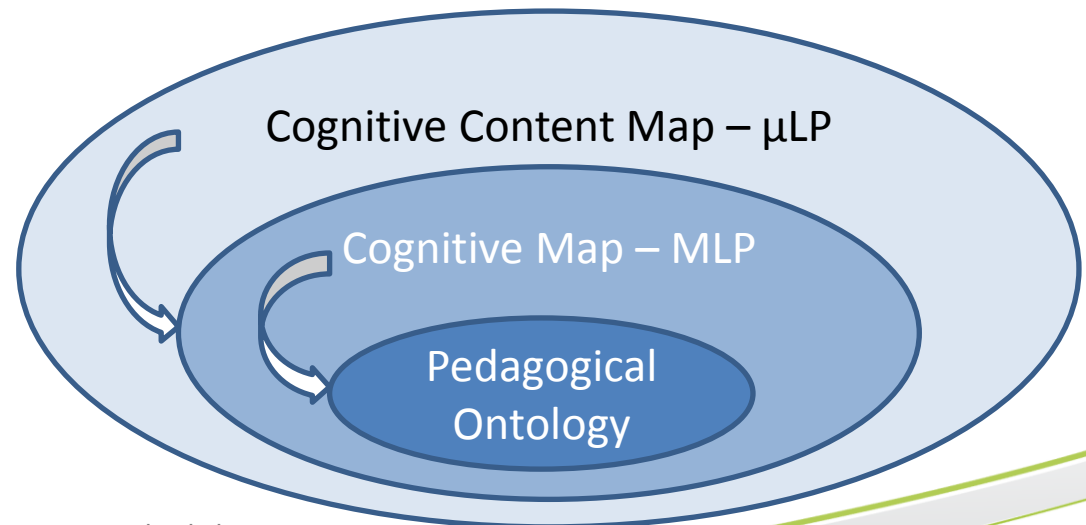

Plus:
Metadata model
Metadata packaging model
Metadata editor/merger/importer

Personalized Web Learning – Example



- A series of video clips covering a technical product by their URI
 - Knowledge objects are
 - O = Overview – name, how does this thing look like
 - I1 – I3 = Introduction – what is this thing doing
 - T1 – T3 = Technical details - how does it work inside
 - M1 – M3 = Maintenance work – what to do if detail X is broken
 - S1 – S3 = Sales pitch – how much does it cost to the outside world
 - P1 – P3 = Production pitch – resources needed
 - W1 – W3 = Wrapup – short summary of details
- Concept container
 - CO consisting of O and I1-I3
 - 3 different C2-x consisting of Tx and Mx
 - CP consisting of S1-S3 and P1-P3
 - CX consisting of W1 – W3

Example continued



- Makro Learning Pathways

- Management
- CO,CP,CW

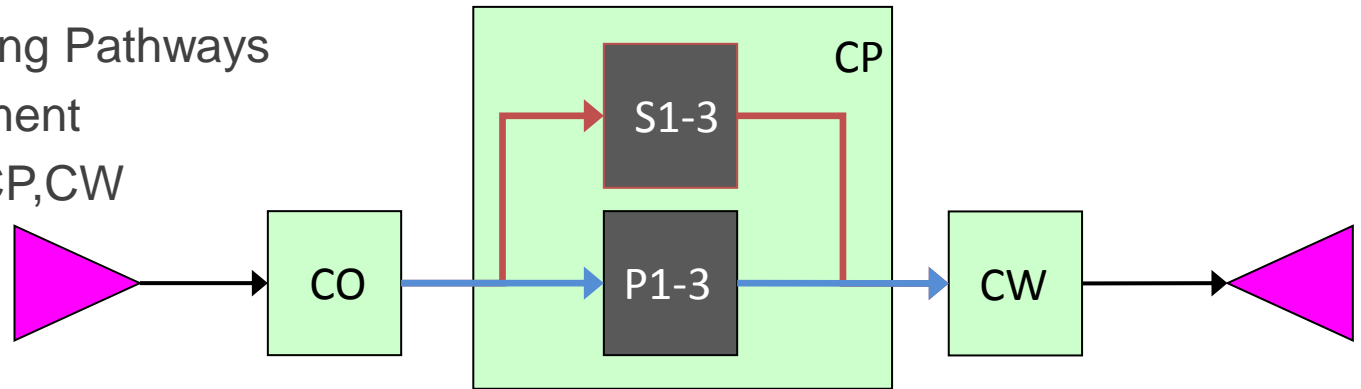

- Tech
- CO,C2-1 ... C2-3,CW

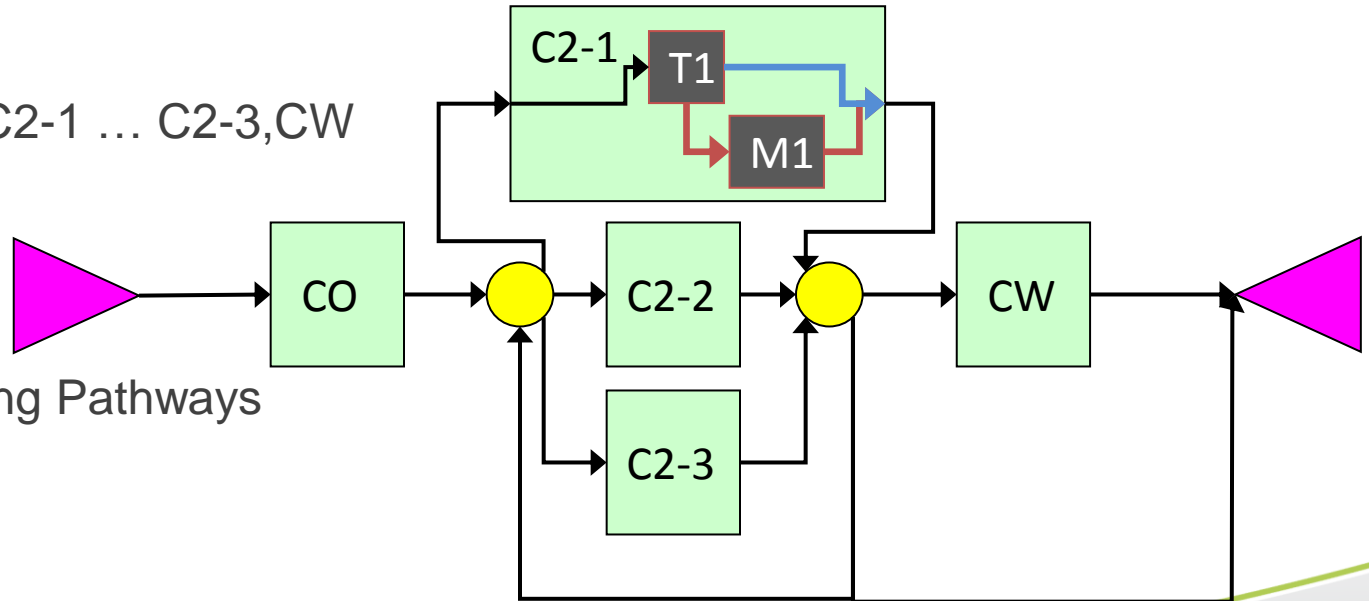

- Micro Learning Pathways

- Internal
- External

Wrapup



- Adaptivity according to
 - learner behavior
 - didactical model or company needs
- The small OER are not copied, but only linked
 - May reside anywhere on the internet (also locally)
- Course may be open – or not at all
 - Depends on the intention of the owner of the INTUITEL system
- A certain learning pathway is not enforced
 - Freedom of choice maintained
 - Cognitive decision of learner needed

Project State



- Overview video available
 - <https://www.youtube.com/watch?v=GbWBJmCFXtw>

- Interfaces available
 - For Download and installation in ILIAS and Moodle
 - Tech spec for other implementations
 - Ontologies available for download

- Proof of recommendation concept in April
 - <https://www.youtube.com/watch?v=hisDyDFpVM0>

- INTUITEL Backend in testing
 - 3 months ahead of schedule

- INTUITEL Tool Suite in testing
 - In schedule

INTUITEL Partners



Hochschule Karlsruhe
Technik und Wirtschaft
UNIVERSITY OF APPLIED SCIENCES



University of
Reading



Fraunhofer

IOSB

Hit

מכון טכנולוגי חולון
Holon Institute of Technology



universität
wien

Faculty of Philosophy and
Educational Sciences

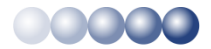

TIE KINETIX
total integrated e-commerce



Universidad de Valladolid



unir

UNIVERSIDAD
INTERNACIONAL
DE LA RIOJA



STEINBEIS-
EUROPA-
ZENTRUM



LEARNTEC



Steinbeis

Contact:

Prof. Dr. Peter A. Henning

**Institute for Computers in Education, Karlsruhe U of Applied Sciences
and Steinbeis University, Berlin**

LEARNTEC Karlsruhe – <http://www.learntec.de>

INTUITEL – <http://www.intuitel.eu>

Peter.Henning@intuitel.eu